



**INTERNATIONAL JOURNAL OF ENGINEERING SCIENCES & RESEARCH
TECHNOLOGY**

Fuzzy Controller Based UPQC for Power Quality Improvement

S.Rajeev ^{*1}, Amit Goswami ², Ankit Dubey ³

^{*1} M.Tech., Power Systems, DIMAT, Raipur Chhattisgarh, India

^{2,3} Assistant Professor, Department of EEE, DIMAT, Raipur, Chhattisgarh, India

rjv.saraswat@gmail.com

Abstract

The paper proposes a unified power quality controller (UPQC) using a fuzzy logic controller (FLC). The results obtained through the FLC are good in terms of dynamic response because of the fact that the FLC is based on linguistic variable set theory and does not require a mathematical model of the system. Also, the tough method of tuning the PI controller is not required for FLC. Simulations are carried out using MATLAB/Simulink to validate the theoretical findings.

Keywords: Power Quality, Voltage Sag, Voltage Swell, Harmonics, Unified Power Quality Conditioner(UPQC), PI Controller, Fuzzy Logic Controller..

Introductions

Power quality determines the fitness of electrical power for consumer devices. The voltage frequency and phase Synchronization allows electrical systems to function in their intended manner without significant loss of life or performance. The term is used to describe electric power that drives an electrical load and the load's ability to function properly. In the absence of proper power, an electrical device (or load) may malfunction, fail prematurely or not operate at all. Power quality can be roughly broken into categories as follows:

1. steady-state voltage magnitude and frequency,
2. voltage sags,
3. grounding,
4. harmonics,
5. voltage fluctuations and flicker,
6. transients, and
7. monitoring and measurement. [1]

The quality of power supply has become a major concern of electricity users. If the quality of power supply is not good then it may result in malfunctions of system, instabilities, short life time, and so on. Poor power quality is mainly due to adjustable speed drives. The power quality disturbances are classified as momentary interruption, voltage sag, voltage swell, impulse, notches, harmonic distortion and flicker. These disturbances may cause malfunctioning of the equipments. To improve the quality of power for non-linear load and voltage sensitive load, UPQC gives the best solutions.

UPQC can simultaneously mitigate the voltage disturbance in source side and the current disturbance in load side. UPQC can compensate for voltage sag, voltage swell, harmonic current, and harmonic voltage. It can control the power flow and the reactive power. However, it cannot compensate the voltage interruption because it has no energy storage in the DC link. [2]

The performance of UPQC mainly depends upon how quickly and accurately compensation signals are derived. Control schemes of UPQC based on PI controller has been widely reported [3-6]. But, the control of UPFC based on the conventional PI control is prone to severe dynamic interaction between active and reactive power flows [3].

This paper proposes replacement of the conventional PI controller by a fuzzy controller (FC). The FC is basically nonlinear and adaptive in nature. The results obtained through FC are superior in the cases where the effects of parameter variation of controller are also taken into account. The Fuzzy Controller is based on linguistic variable set theory and does not require a mathematical model.

Unified power quality conditioner

The provision of both DSTATCOM and DVR can control the power quality of the source current and bus voltage of the load. Also, if the DVR and STATCOM are connected on the DC side, the DC bus voltage can be regulated by the shunt connected DSTATCOM while the DVR supplies the required energy to the load in case of the transient disturbances in source voltage. The configuration of

Unified Power Quality Conditioner (UPQC) is shown in Fig. 1

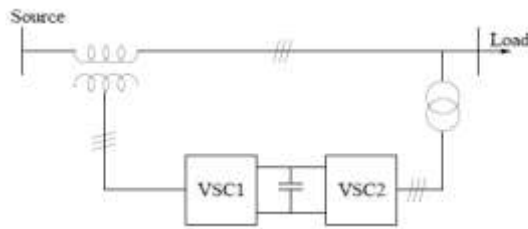

Fig. 1: UPQC Configuration

Control objectives of UPQC

The control objectives of shunt connected converter are as follows-

1. To balance the source currents by injecting negative and zero sequence components required by the load.
2. The compensate for the harmonics in the load current by injecting the required harmonic currents.
3. To control the power factor by injecting the required reactive current (at fundamental frequency).
4. To regulate the DC bus voltage.

The control objectives of series connected converter are as follows-

1. To balance the voltages at the load bus by injecting negative and zero sequence voltages to compensate for those present in the source.
2. To isolate the load bus from the harmonics present in the source voltages, by the way of injecting the harmonic voltages.
3. To regulate the magnitude of the load bus voltage by injecting the required active and reactive components (at fundamental frequency) depending on the power factor on the source side.
4. To control the power factor at the input port of the UPQC (where the source is connected). It is important to note that the power factor at the output port of the UPQC (connected to the load) is controlled by the shunt converter.

Operation of UPQC

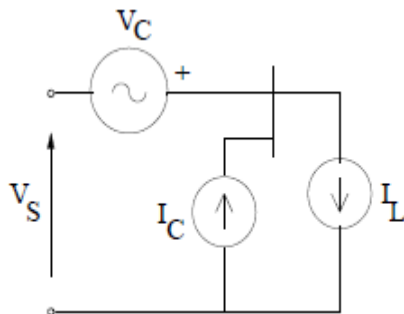

Fig. 2 : UPQC Equivalent Circuit

The operation of a UPQC can be explained from the analysis of the idealized equivalent circuit shown in Fig.2. Here, the series converter is represented by a voltage source VC and the shunt converter is represented by a current source IC. Note that all the currents and voltages are 3 dimensional vectors with phase coordinates. The voltages and currents may contain negative and zero sequence components in addition to the harmonics. Neglecting losses occurring in the converters, we get the relation :

$$\langle V_L, I_C \rangle + \langle V_C, I_S \rangle = 0$$

PI Controller

The general block diagram of the PI speed controller is shown in Figure.

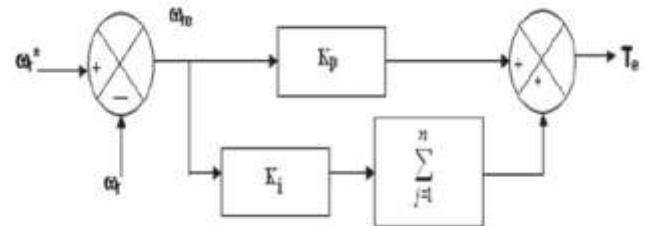

Fig. 3: PI Speed Controller Block Diagram

The output of the speed controller (torque command) at n-th instant is expressed as follows:

$$T_e(n) = T_e(n-1) + K_p \cdot \text{ore}(n) + K_i \cdot \text{iore}(n)$$

Where $T_e(n)$ is the torque output of the controller at the n-th instant, and K_p and K_i the proportional and integral gain constants, respectively. Certain limit of the torque command is imposed as

$$T_{e(n+1)} = \begin{cases} T_{e_{max}} & \text{for } T_{e(n+1)} \geq T_{e_{max}} \\ -T_{e_{max}} & \text{for } T_{e(n+1)} \leq -T_{e_{max}} \end{cases}$$

The gains of PI controller can be selected by many methods such as Ziegler–Nichols method, trial and error method and evolutionary techniques-based searching. The numerical values of these controller gains depend on the ratings of the motor.

Fuzzy logic controller

In FLC, basic control action is governed by a set of linguistic rules. These linguistic rules are determined by the system. As the numerical variables are converted into variables on linguistic basis, mathematical modeling of the system is not required in FC. The FLC consists of three parts: a)fuzzification, b)interference & c)defuzzification. The Fuzzy Controller is characterized as: i) Each input and output with seven fuzzy sets. ii) Triangular membership functions for simplicity. iii) Using continuous universe of discourse for Fuzzification.

- iv) Implication using Mamdani's 'min' operator.
- v) Defuzzification using the 'height' method.

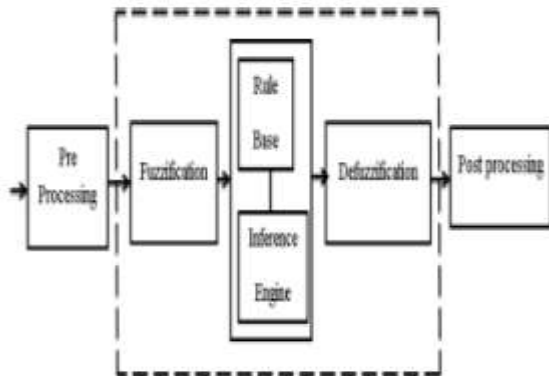

Fig. 4 : Fuzzy Logic Controller

Simulation results and discussion

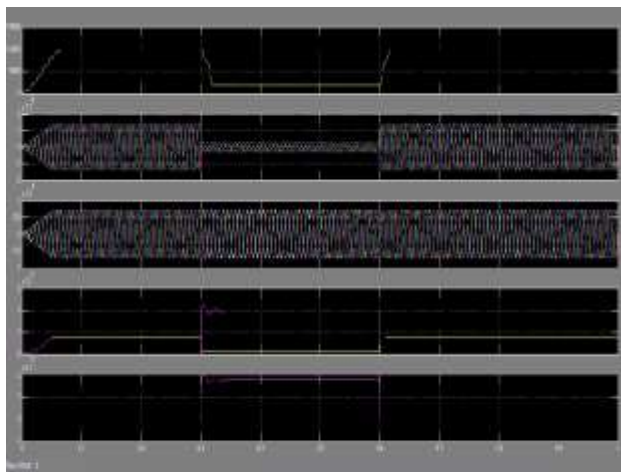

Fig. 5 : Waveforms without UPQC

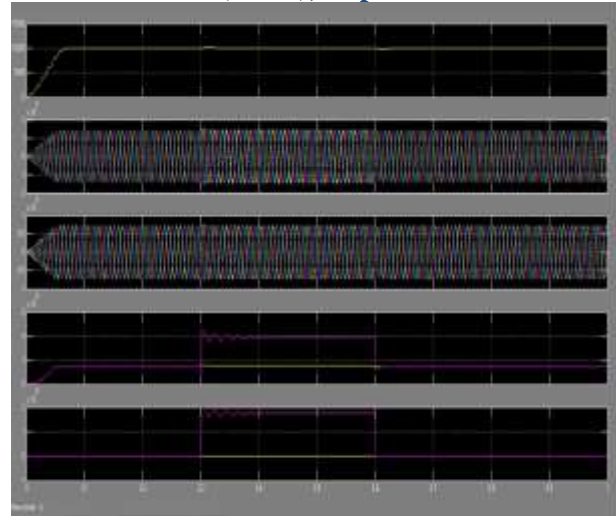

Fig. 6 : Waveforms with UPQC using PI Controller

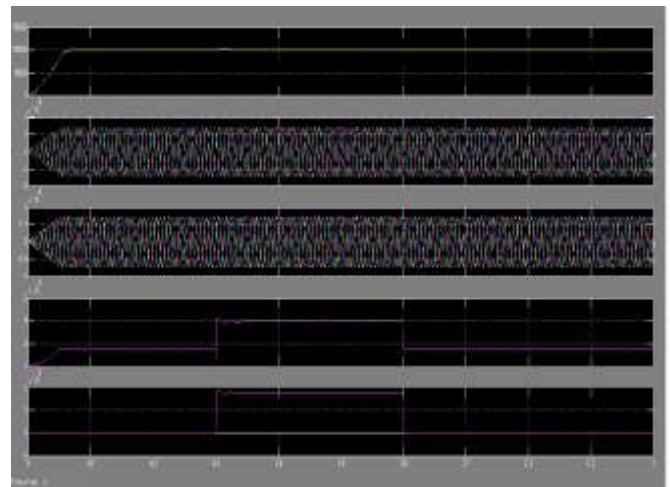

Fig. 7 : Waveforms with UPQC using Fuzzy Logic Controller

In order to test the performance of the UPQC using the proposed FLC, it has been simulated for a standard of 400 V, 50 Hz three-phase AC supply using MATLAB/Simulink. To test the operation of UPQC under the voltage sag and swell conditions, sag in line voltage has been created.

Conclusion

The UPQC has been simulated using the proposed FC. It may be noticed that the source current is distorted before connecting the UPQC and it becomes sinusoidal after connecting the UPQC. It is clear from the simulation results that the UPQC

using FC has simplicity, and is based on sensing only the line currents. The THD of the source current with the proposed FLC is well below 5%, the harmonic limit imposed by IEEE-519 standard.

References

1. *Power Electronics Handbook*, M.H.Rashid, Academic Press.
2. Siah, Hoseynpoor, Najafi, Ebrahimi, "Design and Simulation of UPQC with Super-Capacitor to Energy Storage and Improve Power Quality", *Australian Journal of Basic and Applied Sciences*, 5(3): 674-681, 2011, ISSN 1991-8178
3. Wang H. F., Jazaeri M. and Cao Y. J., "Operating modes and control interaction analysis of unified power flow controller," *IEE Proc. Gener. Transm. Distrib.*, vol. 152, no. 2, pp. 264-270, 2005.
4. Khadkikar V. and Chandra A., "A new control philosophy for a unified power quality conditioner (UPQC) to coordinate load-reactive power demand between shunt and series inverters," *IEEE Trans. Power Deliv.*, vol. 23, no. 4, pp. 2522-2534, 2008.
5. Kolhatkar Y. Y. and Das S. P., "Experimental investigation of a single-phase UPQC with minimum VA loading," *IEEE Trans. Power Deliv.*, vol. 22, no. 1, pp. 373-380, 2007.
6. Basu M., Das S. P. and Dubey G. K., "Comparative evaluation of two models of UPQC for suitable interface to enhance power quality," *Elect. Power Syst. Res.*, vol. 77, no. 7, pp. 821-830, 2007.